

Technical Specification

Model : HD17V5 Operating weight : 1,780kg Bucket capacity : 0.024m³~0.055m³[Standard 0.044m³]

ENGINE

Model YANMAR 3TNV74
 Rated output 10.5kW/2,300min-1
 Max. torque 51.8N·m/1,800min-1

DIMENSIONS

Overall length 3,450mm
 Overall height 2,380mm
 Overall width 1,300mm (Min.990mm)
 Max. ground clearance 170mm
 Tail slewing radius 650mm
 Crawler length 1,570mm
 Shoe width 230mm

TRAVEL&SWING SYSTEM

Travel speed 2.1/4.0km/h
 Max. swing speed 8.5min-1
 Grade ability 58% (30°)
 Ground pressure 30kPa(0.30kgf/cm²)

DIGGING FORCE

Bucket digging force 16.4kN
 Arm digging force 9.6kN

CAPACITY

Hydraulic tank 16L (reference capacity)
 Fuel tank 22L

HYDRAULIC SYSTEM

Pumps Double variable piston pump and gear pump
 Swing motor Orbit slewing motor with swing brake
 Travel motor Variable displacement plunger motor
 Control valves 9 section multiple control valves
 Max. pressure/..... 20.6MPa (210kgf/cm²)
 setting

0988632EN

DIMENSION (mm)

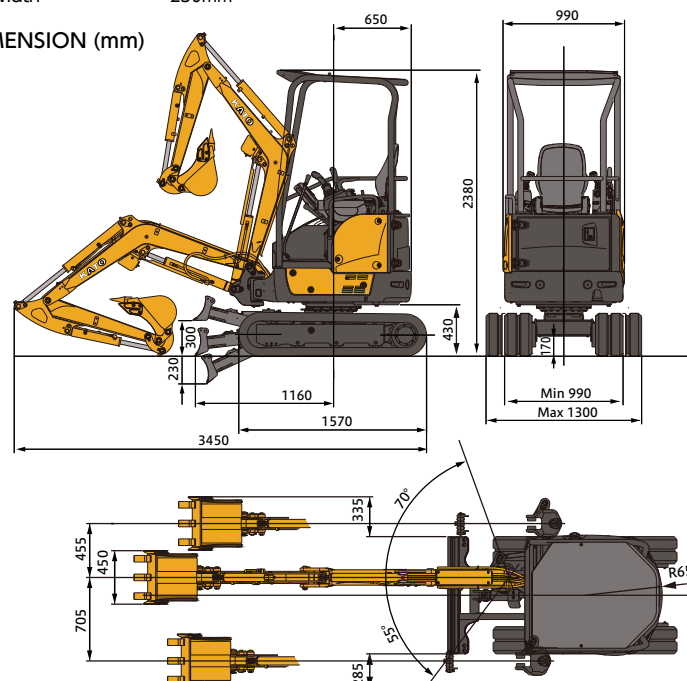

WORKING RANGE (mm) [Standard/Long arm]

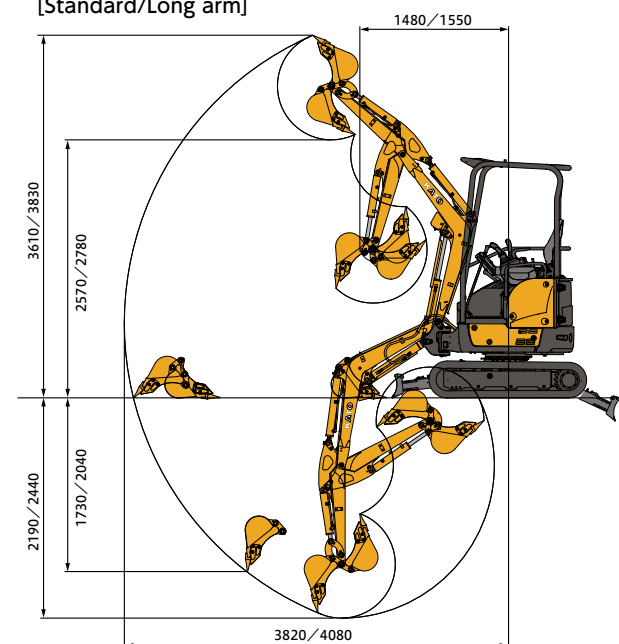

STANDARD AND OPTIONAL EQUIPMENTS

○Standard ●Optional

Safety equipment

ROPS canopy	○
TOPS canopy	●
Safety lock lever	○
Retractable seat-belt	○
Boom working light	○
LED working light for 4-post canopy	●
Automatic parking brake (slewing table)	○
Traveling Alarm	●

Piping and others

1st aux. piping for attachment (W/A selectable)	●
2nd aux. piping for attachment ※1	●
Aux. piping proportional control	●
Stop valve for 1st aux piping port	●
Pattern change valve (AB,AF)	●
Relief valve for spare port(13.7MPa) ※2	●
Relief valve for spare port(17.2MPa) ※2	●

Traveling equipment

230mm rubber shoe	○
230mm steel shoe	●
230mm steel shoe +pads	●
Traveling frame undercover	○

System

Variable gauge undercarriage	○
------------------------------	---

Maintenance

Double element air cleaner	○
Cartridge type return filter	○
Fuel filter	○
Castle nut for adjustment (boom tip)	○

※1 Unavailable to select the 2nd aux piping alone
 ※2 Cannot be installed at the same time

Operation seat

12V electric supply port	○
Cup holder	○
Multiple one-key	○
Analogue monitor	○
Seat suspension	●

Canopy

4-post canopy (ROPS)	○
2-post canopy (TOPS)	●

Working equipment

Bucket	0.024m ³	●
	0.033m ³	●
	0.044m ³	○
	0.055m ³	●
Arm	STD Arm	○
	Long Arm (+250mm)	●
Dozer blade	Reinforced type	○
	Additional dozer blade	●
	Additional counterweight(+100kg)	●

SPECIFICATION AND COMBINATION OF BUCKET

Type	Bucket				
Bucket capacity (JIS M3) (m ³)	0.024	0.033	0.044	0.055	
Bucket width (mm)	without side cutter	250	300	400	450
	with side cutter	300	350	450	500
Number of bucket teeth	2	3	3	3	
Standard arm	●	●	●	□	
Long arm	●	●	×	×	

● : General purpose □ : Light work × : Unusable

SHOE

Type	Rubber	Steel
Shoe width (mm)	230	
Overall width (mm)	[Max./Min.]1,300 / 990	
Ground pressure (kPa)	30	31

● Before using this machine, read the instruction manual precautions thoroughly to operate it correctly
 ● Specifications are subject to change without notice for improvement purposes
 ● Photographs shown in the catalog were taken for publication and therefore may differ in some cases from actual objects
 ● When operating the mini excavator, wear clothing and equipment in accordance to local legal and safety regulations.

● Contact for enquiry:



KATO WORKS CO., LTD.

9-37, Higashi-ohi 1-chome, Shinagawa-ku, Tokyo, 140-0011, Japan
 Tel.: Head Office: Tokyo +81(0)3 3458-1111
 Overseas Marketing Department: Tokyo +81(0)3 3458-1115 / FAX: Tokyo +81(0)3 3458-1163
www.kato-works.co.jp



KATO

MINI EXCAVATOR

V FIVE HD17



Travels smoothly in confined spaces

Powerful Strong Reliable

This compact machine fits various job sites

Workability

Extendable undercarriage

This undercarriage design is efficient for transportation and traveling in confined spaces ensuring compactness and high stability.



990mm



1,300mm

Retractable dozer blade extension (opt)

The blade width can be easily adjusted, offering the flexibility to fit the job. Adjustment is simple and easily done with two fastening pins.



Fully versatile easy skimming work

The closer distance between bucket teeth and dozer blade allows it to skim the ground easier.



Removable side cover

Easy to clean radiator.



Easy refueling

The fuel filler port is placed at a lower position for easy refueling.



Compact body & wide working range

The perfect combination of compactness and wide working range allows it to access confined spaces and enables for excellent performance. It also secures enough digging height for truck loading.



Improvement of Max. dipping depth by

4%

(In comparison to previous model)

Maintenance

Wide openable engine cover

The fully openable engine cover provides great access to various components. Daily maintenance such as air filter cleaning, engine oil replacement become easier.



Safety

Engine start system & safety lock system

The engine is turned on when that lever is in the neutral position. Auto-parking brake is activated when the lock lever is raised. (Including dozer blade and swing) It offers high operating safety and prevents unexpected movements.



ROPS compliant 4-post canopy

4-post canopy with a retractable seat belt is available as standard feature. Safety of operator has significantly improved. (Fasten your seat belt when you operate)



(Analysis model)

High stress

Small stress

Comfortability

Comfortable operator's station

The operator position is optimized and provides the best comfortability thanks to foot space being increased by more than 10% in comparison to previous model.



Side Stability is increased

7%

(In comparison to previous model)

10%

(In comparison to previous model)

12V electric supply port



Cup holder



Durability

Frame protection

Durability and sturdiness are increased all around the body by casting.



Working light under the boom

The light installed under the boom is protected from damage.



Reinforced dozer blade

The box-shaped dozer provides higher rigidity.

